



ISO-DIN pocket 1980-2012

Infiniti, Lexus, Mercury, Mitsubishi, Nissan, Subaru, Toyota

KIT FEATURES

- Pocket provision for ISO DIN installations
- Holds (3) CD jewel cases
- Includes USB charging adapter

KIT COMPONENTS

- A) Pocket • B) Nissan/Infiniti/Mercury trim • C) Mitsubishi trim • D) Subaru trim • E) Toyota/Lexus trim • F) (4) # 8 x 1/4" Phillips screws
- G) USB socket/cable

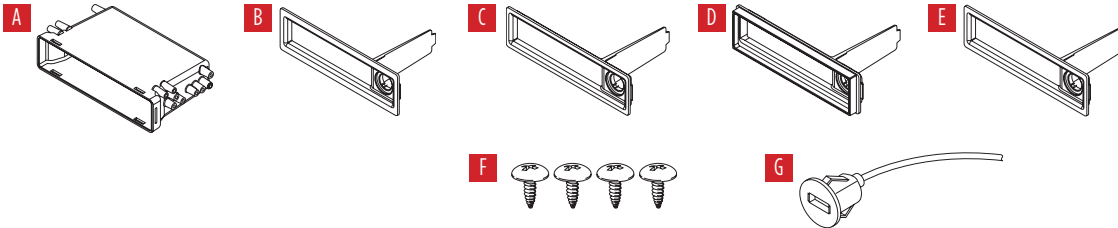

TABLE OF CONTENTS

Applications.....	2
Kit Assembly	2-3

WIRING & ANTENNA CONNECTIONS (sold separately)

- Please use the vehicle fit guide available at metraonline.com

TOOLS REQUIRED

- Phillips screwdriver

Attention! With the key out of the ignition, disconnect the negative battery terminal before installing this product. Ensure that all installation connections are secure before cycling the ignition to test this product.

APPLICATIONS

Infiniti

G201999-2002
G201991-1996
I301996-1999
I301993-1997
M301990-1992
Q451990-1996

Lexus

ES 2501990-1991
LX 4501996-1997

Mercury

Villager1993-2002
----------	----------------

Mitsubishi

3000 GT1991-1999
Diamante1992-2004
Diamante Wagon1993-1995
Eclipse1995-2005
Eclipse Spyder1995-2005
Galant (w/ separate a/c)2004-2012
Galant1994-1998
Mirage1997-2002
Montero1997-2006
Montero Sport2000-2004
Outlander2003-2006

Nissan

200SX1995-1998
200SX1980-1988
240SX1989-1998
Altima1993-2001
Axxess 1989-1990
Frontier1998-2004
Hardbody Pickup1994-1997
Maxima1982-2003
(w/wrap around radio)2000-2003
Maxima1995-1999
Maxima1987-91
Maxima1982-1984
Pathfinder SE2003-2004
Pathfinder (w/o nav)2001-2002
Pathfinder1994-2000
Pulsar1983-1990
Quest1993-2003
Sentra1995-1999
Sentra1982-86
Stanza1982-1992
Xterra2000-2004

Subaru

Baja2003-2006
Forester1998-2008
Impreza1993-2007
Legacy1995-2004
Outback1998-2004
Outback Sport2005-2006

Toyota

4-Runner1984-2002
Avalon1995-1999
Camry1983-1991
Camry1992-2001
Camry Solara1999-2003
Celica1982-1993
Celica1994-1999
Corolla (coupe/hatchback)	..1982-1983
Corolla1984-1997
Cressida1981-1992
Land Cruiser (without nav)	2000-2002
Land Cruiser1993-1999
Land Cruiser1988-1992
MR21985-1995
Paseo1992-1997
Pickup1984-1995
Previa1991-1997
Rav-42001-2002
Sequoia2001-2002
Sienna1996-2003
Supra1983-1992
Supra1994-1998
T-1001993-1998
Tacoma1995-2004
Tercel1983-1986
Tercel1987-1998
Tundra2000-2002
Van1984-1990

KIT ASSEMBLY

1. Remove the fuse holder cover and pigtail from the **USB charging socket** fuse holder, then remove the fuse.
2. Insert and click in the socket to the appropriate **faceplate**, lining up the keyway in the socket with the groove in the faceplate. Reference the legend to locate the appropriate **faceplate**. (Figure A)
3. Knock out the rear of the **pocket** to allow the socket wiring to go through, then route the wiring through the hole. (Figure B)

Continued on the next page

Legend

Refer to the letter on the back of the faceplate to locate the appropriate faceplate.

N - Nissan/Infiniti/Mercury trim

M - Mitsubishi trim

S - Subaru trim

T - Toyota/Lexus

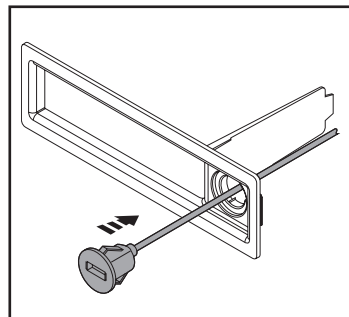

(Figure A)

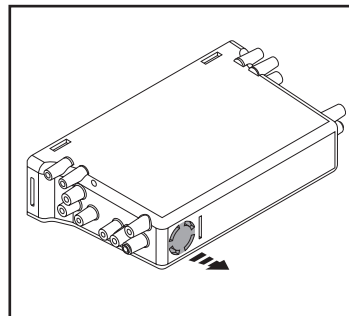

(Figure B)

KIT ASSEMBLY

4. Reinstall the fuse and fuse holder cover back onto the USB charging socket fuse holder.
5. Clip the **faceplate** onto the **pocket**, ensuring that the rear tab on the **faceplate** lines up with the groove in the pocket. (Figure C)

Note: Once the faceplate clips in, it cannot be unclipped without damaging the pocket.

6. Remove the brackets from the factory radio.
7. Attach the **pocket** to the brackets using the (4) #8 x 3/8" Phillips screws provided. (Figure D)
8. Remove the metal DIN sleeve and trim ring from the aftermarket radio.

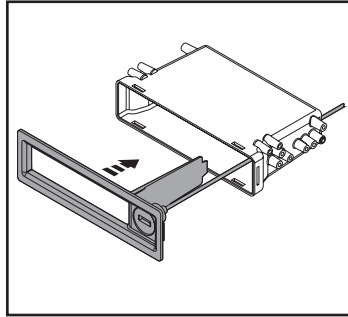

(Figure C)

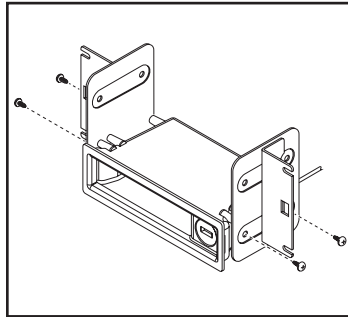

(Figure D)

9. Slide the radio into the bracket/pocket assembly, and then secure it using the screws supplied with the radio. (Figure E)
10. Connect the **Black** wire from the **USB charging socket** to chassis ground.
11. Connect the **Red** wire from the **USB charging socket** to either battery power, or accessory power, depending on the desired choice.
12. Locate the factory wiring harness and antenna connector in the dash and complete all necessary connections to the radio. Metra recommends using the proper mating adapter from Metra. Test the radio for proper operation.
13. Secure the completed assembly into the dash using the factory screws, and then reassemble the dash in reverse order of disassembly.

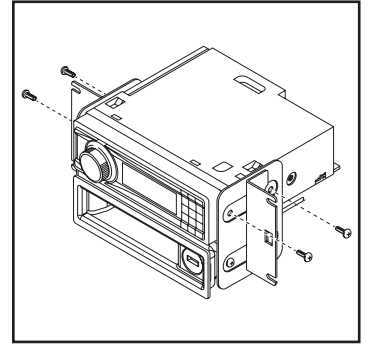

(Figure E)



88-00-9007
INSTALLATION INSTRUCTIONS



Having difficulties? We're here to help.



Contact our Tech Support line at:

386-257-1187



Or via email at:

techsupport@metra-autosound.com

Tech Support Hours (Eastern Standard Time)

Monday - Friday: 9:00 AM - 7:00 PM

Saturday: 10:00 AM - 7:00 PM

Sunday: 10:00 AM - 4:00 PM



KNOWLEDGE IS POWER

Enhance your installation and fabrication skills by enrolling in the most recognized and respected mobile electronics school in our industry. Log onto www.installerinstitute.edu or call 386-672-5771 for more information and take steps toward a better tomorrow.



**Metra recommends MECP
certified technicians**



ISO-DIN cavidad 1980-2012

Infiniti, Lexus, Mercury, Mitsubishi, Nissan, Subaru, Toyota

(ver aplicaciones en la página 2)

CARACTERÍSTICAS DEL KIT

- Provisión de cavidad para las instalaciones de DIN ISO
- Espacio para (3) estuches plásticos de CD
- Incluye conector de carga USB

COMPONENTES DEL KIT

- A) Cavidad • B) Moldura Nissan/Infiniti/Mercury • C) Moldura Mitsubishi • D) Moldura Subaru • E) Moldura Toyota/Lexus
- E) Tornillos Phillips # 8 de 1/4" (4) • F) Conector de carga USB con entradas

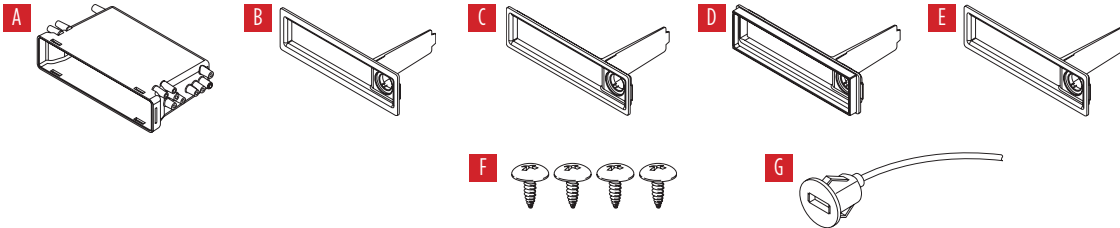

INDICE

Aplicaciones	2
Ensamble del kit	2-3

CABLEADO Y CONEXIONES DE ANTENA

(se venden por separado)

Por favor, utilice la guía de ajuste de vehículo
Árnés de cableado: Visite metraonline.com para
conocer las opciones de interfaz de control del
volante y audio / video.

HERRAMIENTAS REQUERIDAS

- Destornillador Phillips

¡Atención! Deje que el vehículo se asiente con la llave fuera del encendido durante unos minutos antes de quitar la radio de fábrica. Al probar el equipo del mercado de accesorios, asegúrese de que todo el equipo de fábrica esté conectado antes de encender el llave de encendido.

APLICACIONES

Infiniti

G20	1999-2002
I30	1996-1999
J30	1993-1997
M30	1990-1992
Q45	1990-1996

Lexus

ES 250	1990-1991
LX 450	1996-1997

Mercury

Villager	1993-2002
----------------	-----------

Mitsubishi

3000 GT	1991-1999
Diamante	1992-2004
Diamante Wagon	1993-1995
Eclipse	1995-2005
Eclipse Spyder	1995-2005
Galant (con a/c separado)	2004-2012
Galant	1994-1998
Mirage	1997-2002
Montero	1997-2006
Montero Sport	2000-2004
Outlander	2003-2006

Nissan

200SX	1995-1998
240SX	1989-1998
Altima	1993-2001
Frontier	1998-2004
Hardbody Pickup	1994-1997
Maxima	2000-2003 (sin envolver la radio)
Maxima	1995-1999
Maxima	1987-1991
Pathfinder SE	2003-2004
Pathfinder (sin nav)	2001-2002
Pathfinder	1994-2000
Pulsar	1987-1990
Quest	1993-2003
Sentra	1995-1999
Stanza	1987-1992
Xterra	2000-2004

Subaru

Galant	2003-2006
Forester	1998-2008
Impreza	1993-2007
Legacy	1995-2004
Outback	1998-2004
Outback Sport	2005-2006

Toyota

4-Runner	1984-2002
Avalon	1995-1999
Camry	1983-1991
Camry	1992-2001
Camry Solara	1999-2003
Celica	1982-1993
Celica	1994-1999
Corolla (coupe/hatchback) ..	1982-1983
Corolla	1984-1997
Cressida	1981-1992
Land Cruiser (sin nav) 2000-2002	
Land Cruiser	1993-1999
Land Cruiser	1988-1992
MR2	1985-1995
Paseo	1992-1997
Pickup	1984-1995
Previa	1991-1997
Rav-4	2001-2002
Sequoia	2001-2002
Sienna	1996-2003
Supra	1983-1992
Supra	1994-1998
T-100	1993-1998
Tacoma	1995-2004
Tercel	1983-1986
Tercel	1987-1998
Tundra	2000-2002
Van	1984-1990

ENSAMBLE DEL KIT

1. Retire la cubierta del portafusibles y el cable flexible de conexión del portafusibles en el conector de carga USB; posteriormente, retire el fusible.
2. Inserte y conecte en el conector de la placa frontal adecuada, alineando la ranura en el conector con la muesca en la placa frontal. Tome la leyenda como referencia para ubicar la placa frontal adecuada. (Figura A)
3. Retire la parte posterior de la cavidad para permitir que pase el cableado del conector; posteriormente, pase el cableado a través del orificio. (Figura B)

Continúa en la siguiente página

Leyenda

Consulte la letra en la parte posterior de la placa frontal para ubicar la placa frontal adecuada.

N- Nissan/Infiniti/Mercury trim
M - Mitsubishi trim
S- Subaru trim
T - Toyota/Lexus

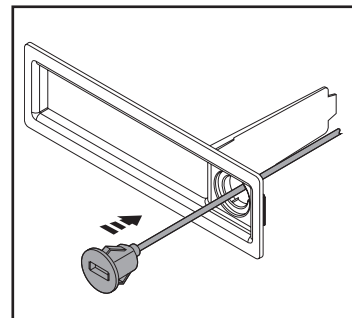

(Figura A)

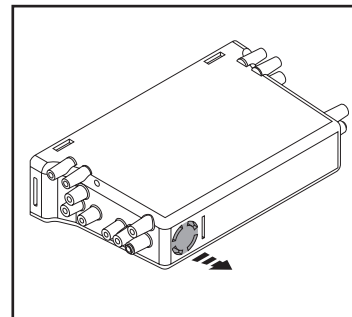

(Figura B)

ENSAMBLE DEL KIT (CONT.)

4. Reinstale el fusible y la cubierta del portafusibles en el portafusibles del conector de carga USB.

5. Conecte la **placa frontal** en la **cavidad**, asegurándose de que la lengüeta posterior de la **placa frontal** se alinee con la ranura de la cavidad. (Figura C)

Nota: Cuando la placa frontal esté enganchada, no será posible desengancharla sin dañar la cavidad.

6. Retire los soportes del radio de fábrica.

7. Fije la **cavidad** a los soportes con los (4) tornillos Phillips #8 de 3/8" incluidos. (Figura D)

8. Quite la manga de metal DIN y el anillo de moldura del radio genérico.

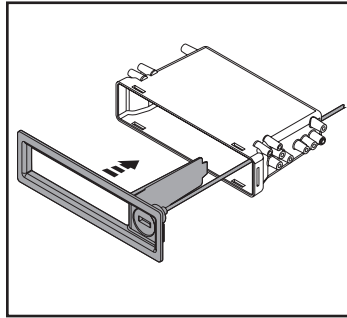

(Figura C)

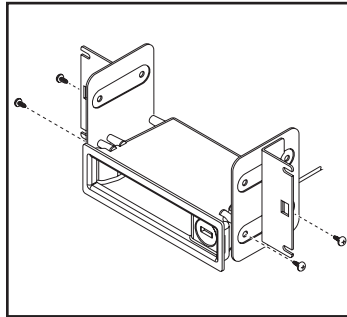

(Figura D)

9. Deslice el radio hacia adentro del ensamblaje del soporte/cavidad y después, sujételo usando los tornillos incluidos con el radio. (Figura E)

10. Conecte el cable **negro** del **conector de carga USB** a la conexión de tierra del chasis.

11. Conecte el cable **rojo** del **conector de carga USB** a la batería o a la fuente de poder de accesorios, según lo prefiera.

12. Localice el arnés de cableado de fábrica y el conector de la antena en el tablero y realice todas las conexiones necesarias al radio. Metra recomienda el uso de un adaptador de acoplamiento adecuado de Metra. Pruebe el radio para asegurarse de que funciona bien.

13. Fije el ensamblaje completo al tablero usando los tornillos de fábrica; posteriormente, vuelva a ensamblar el tablero en el orden inverso de cómo lo desarmó.

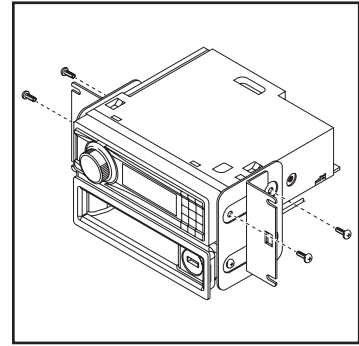

(Figura E)



88-00-9007
INSTRUCCIONES DE INSTALACIÓN



¿Tienes dificultades? Estamos aquí para ayudar.



Póngase en contacto con nuestra
línea de soporte técnico en:
386-257-1187



O por correo electrónico a:
techsupport@metra-autosound.com

Horas de soporte técnico (hora estándar del este)

Monday - Friday: 9:00 AM - 7:00 PM

Saturday: 10:00 AM - 7:00 PM

Sunday: 10:00 AM - 4:00 PM



KNOWLEDGE IS POWER

Enhance your installation and fabrication skills by enrolling in the most recognized and respected mobile electronics school in our industry. Log onto www.installerinstitute.edu or call 386-672-5771 for more information and take steps toward a better tomorrow.



**Metra recomienda MECP
técnicos certificados**