



Ram 1500/2500/3500, Chassis Cab 3500/4500/5500 (with 8.4" touchscreen) 2013-2018 Ram Classic 1500 (with 8.4" touchscreen) 2019-2022

Trailer brake control system not retained

Visit MetraOnline.com for more detailed information about the product and up-to-date vehicle specific applications

KIT FEATURES

- ISO DDIN radio provision
- Retains factory climate control buttons and adds buttons for lost functions with access to vehicle personalization menus
- Built in OLED screen displays visual status of climate functions such as temperature, fan speed, and vent mode that were displayed on the factory screen
- All in one interface to retain climate control functions, factory amplifier, and steering wheel controls
- Painted scratch resistant matte black with chrome accents

KIT COMPONENTS

- A) Radio trim panel • B) Radio brackets • C) Display screen and button assembly • D) #8 x 1/2" Phillips screws (4) • E) Panel clips (4)
- F) Interface buttons: blanks (5) and with graphics (5) (not shown)

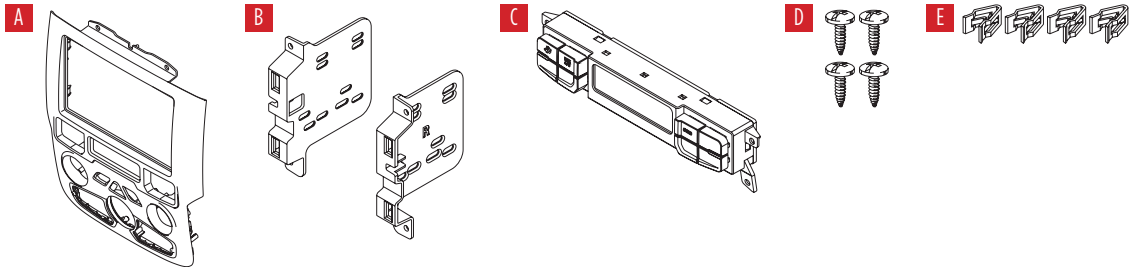

TABLE OF CONTENTS

Dash Disassembly.....	2-3
Kit Preparation.....	4-6
Kit Assembly	7
Axxess Interface Installation	8-18

WIRING & ANTENNA CONNECTIONS

Wiring Harness: Axxess interface built into display creen

Antenna Adapter: Included with kit

TOOLS REQUIRED

- Panel removal tool • Phillips screwdriver
- 9/32" socket wrench • T-20 Torx driver

ATTENTION: With the key out of the ignition, disconnect the negative battery terminal before installing this product. Ensure that all installation connections, especially the air bag indicator lights, are plugged in before reconnecting the battery or cycling the ignition to test this product. **NOTE:** Refer also to the instructions included with the aftermarket accessory before installing this device.

DASH DISASSEMBLY

1. Remove the rubber tray liner inside the tray at the top center of the dash, then remove (2) Torx T-20 screws exposed. (Figure A)
2. Remove the rubber tray liner from inside the small pocket on the passenger side of the center dash panel, then remove (1) Torx T-20 screw exposed. (Figure B)

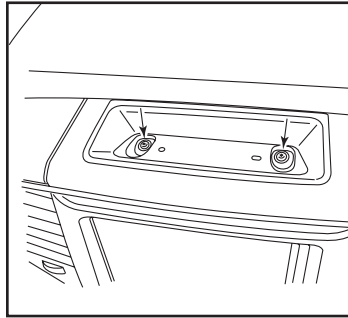

(Figure A)

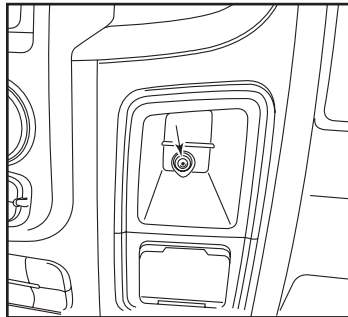

(Figure B)

3. For models with a center console:
 - a. Remove the rubber liner from the storage tray in front of the center console, then remove (2) Phillips screws exposed. (Figure C)
 - b. Remove the rubber liner from the middle of the center console, then remove (1) Phillips screw exposed. (Figure C)
 - c. Remove the rubber liner from the rear of the center console, then remove (2) Phillips screws exposed. (Figure C)
 - d. Unsnap and remove the top of the center console.

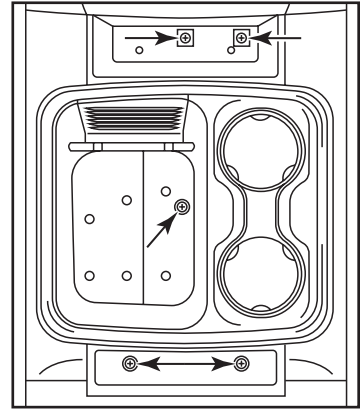

(Figure C)

Continued on the next page

DASH DISASSEMBLY (CONT.)

4. Unsnap and remove the entire center dash panel. (Figure D)
5. Remove (4) 9/32" screws securing the radio/display screen. Slide the screen out, then unplug & remove. (Figure E)
6. The factory rear support will need to be cut or removed to allow space for the aftermarket radio. Different variations of this support may require additional cutting. (Figure F)

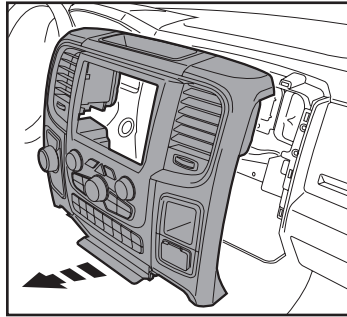

(Figure D)

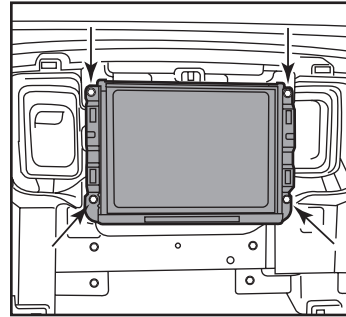

(Figure E)

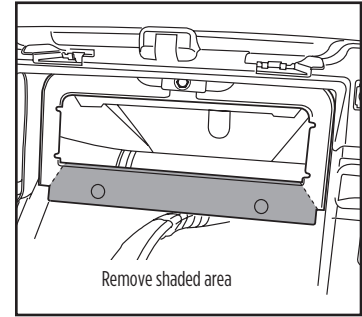

(Figure F)

Continue to Kit Preparation

KIT PREPARATION

From the factory center dash panel:

1. Remove (13) Phillips screws securing the radio/climate control panel, then remove. (Figure A)
2. Remove the (3) radio and climate control knobs by pulling them out of the panel (Figure B)
3. Remove the (5) Torx T-? screws from the back cover of the radio/climate control assembly. (Figure C)

Continued on the next page

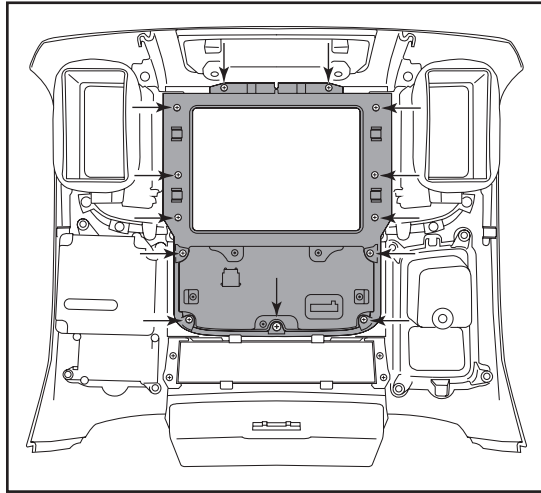

(Figure A)

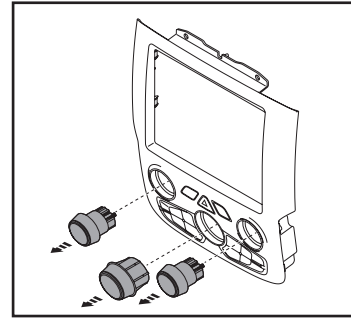

(Figure B)

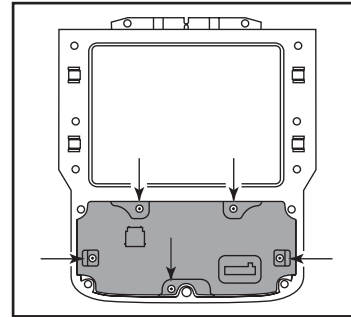

(Figure C)

KIT PREPARATION (CONT.)

From the factory center dash panel: (cont.)

4. Remove the radio/climate control assembly from the dash panel (Figure D)
5. Remove the light pipes from the dash panel. (Figure E)

To the 95-6558B center dash panel:

6. Install the light pipes into the dash panel (Figure F)

Continued on the next page

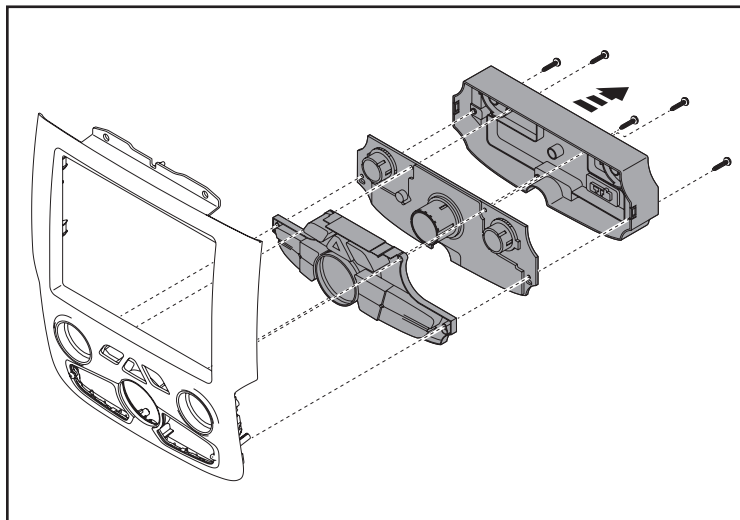

(Figure D)

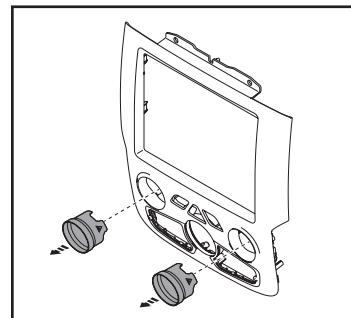

(Figure E)

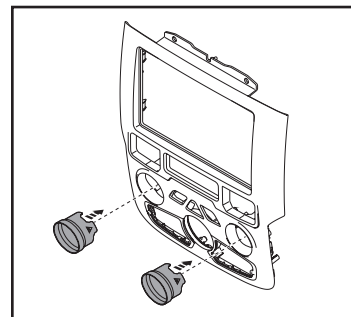

(Figure F)

KIT PREPARATION (CONT.)

To the 95-6558B center dash panel: (cont.)

7. Install the radio/climate control assembly into the dash panel using the (5) factory screws (Figure G)
8. Install the (3) knobs in the panel (Figure H)
9. Place the **radio trim panel** onto the factory panel, then secure using (9) of the factory screws removed in step 1. Use the (4) included #8 x 1/2" Phillips screws to secure the **display screen and button assembly** last. (Figure I)

Continue to Kit Assembly

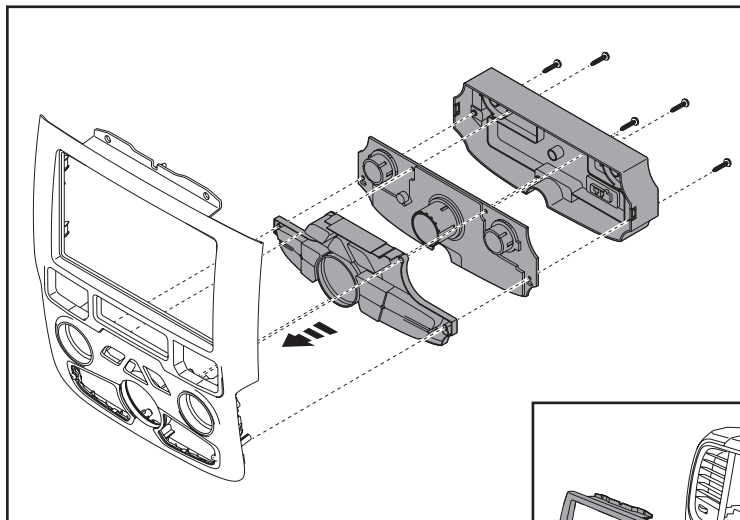

(Figure G)

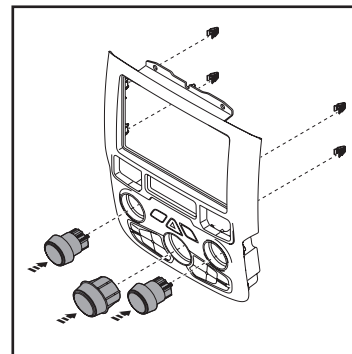

(Figure H)

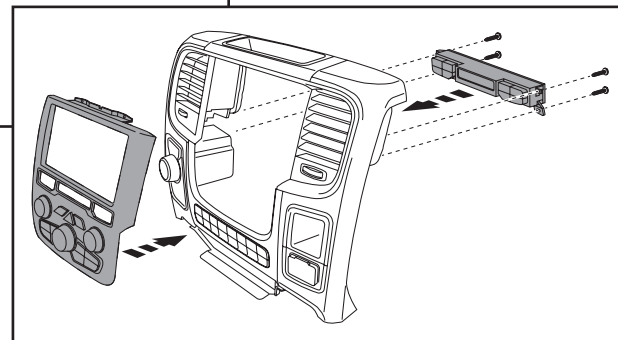

(Figure I)

KIT ASSEMBLY

1. Secure the **radio brackets** to the radio using the screws supplied with the radio, and then secure into the dash opening. (Figure A)

*Continue to Axxess
Interface Installation*

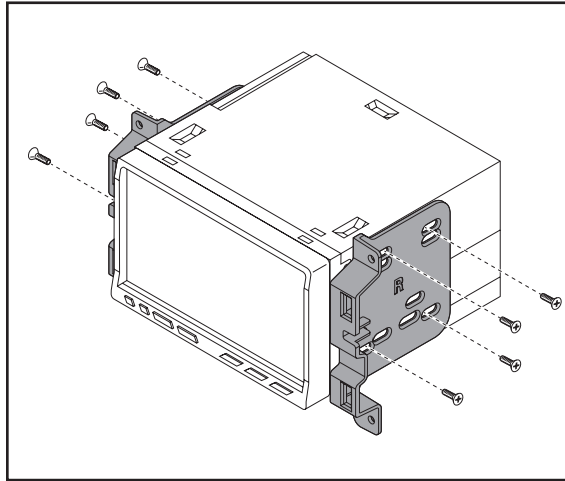

(Figure A)

AXXESS INTERFACE INSTALLATION

INTERFACE FEATURES

- Provides accessory power (12-volt 10-amp)
- Retains R.A.P. (retained accessory power)
- Provides illumination, parking brake, reverse, and speed sense outputs
- Retains audio controls on the steering wheel
- Allows retention and adjustment of the personalization options
- Retains safety chimes
- Retains the factory backup camera
- Retains the factory AUX-IN jack (base models only)
- Can be used in amplified or non-amplified models
- Retains balance and fade*
- Micro-B USB updatable

** Non-amplified models only*

INTERFACE COMPONENTS

- Axxess interfaces
- 6558 harness (LD-BX-CH5)
- 16-pin harness (LD-2NAVAMP)
- Hazard harness (LD-CHRYTAC)
- 3.5mm adapter

TABLE OF CONTENTS

Connections.....	9-10
Installation	11
Programming.....	12
Steering wheel control settings.....	13-16
Factory control panel button functions.....	17
Troubleshooting.....	18

TOOLS REQUIRED

- Crimping tool and connectors, or solder gun, solder, and heat shrink
- Tape • Wire cutter • Zip ties

Attention! This interface will work with models that are either non-amplified, or amplified. Please follow the instructions carefully for your model vehicle. Failure to do so will result in either no sound, or low sound. If you are unsure if your vehicle is factory amplified or not, please contact your local dealership.

CONNECTIONS

For models without a factory amplifier:

From the 16-pin harness to the aftermarket radio, connect the:

- **Red** wire to the accessory wire.
- **Blue/White** wire to the amp turn on wire.
- **Orange/White** wire to the illumination wire (if applicable).

Attention! The following (4) wires are reversed on purpose. These wires will not match “color code” to the aftermarket radio.

- **Gray** wire to the rear right positive speaker output.
- **Gray/Black** wire to the rear right negative speaker output.
- **White** wire to the rear left positive speaker output.
- **White/Black** wire to the rear left negative speaker output.

The following (3) wire are for multimedia/navigation radios that require them.

- **Blue/Pink** wire to the speed sense wire.
- **Green/Purple** wire to the reverse wire.
- **Light Green** wire to the parking brake wire.
- Tape off and disregard the following (5) wires, they will not be used in this application: **Brown, Green, Green/Black, Purple, Purple/Black**
- Disregard the 4-pin harness, it will not be used in this application.

From the 6558 harness to the aftermarket radio, connect the:

- **Black** wire to the ground wire.
- **Yellow** wire to the battery wire.
- **Gray** wire to the front right positive speaker output.
- **Gray/Black** wire to the front right negative speaker output.
- **White** wire to the front left positive speaker output.
- **White/Black** wire to the front left negative speaker output.
- **Yellow** RCA jack to the backup camera input (if applicable).
- **Red & White** RCA jacks to the audio AUX-IN jacks (only if the factory AUX-IN jack is desired to be used).
- Connect the (2) 4-pin connectors together.
- Tape off and disregard the following (2) wires, they will not be used in this application: **Blue/White** labeled “500L amp turn on”, **Red**
- Disregard the DIN jack, it will not be used in this application.

Continued on the next page

For models with a factory amplifier:

From the 16-pin harness to the aftermarket radio, connect the:

- **Red** wire to the accessory wire.
- **Blue/White** wire to the amp turn on wire.
- **Orange/White** wire to the illumination wire (if applicable).

The following (3) wire are for multimedia/navigation radios that require them.

- **Blue/Pink** wire to the speed sense wire.
- **Green/Purple** wire to the reverse wire.
- **Light Green** wire to the parking brake wire.
- Tape off and disregard the following (9) wires, they will not be used in this application:
Gray, Gray/Black, White, White/Black, Green, Green/Black, Purple, Purple/Black, Brown

From the 6558 harness to the aftermarket radio, connect the:

- **Black** wire to the ground wire.
- **Yellow** wire to the battery wire.
- **Gray** wire to the front right positive speaker output.
- **Gray/Black** wire to the front right negative speaker output.
- **White** wire to the front left positive speaker output.
- **White/Black** wire to the front left negative speaker output.
- Connect the 4-pin harness to the main 52-pin connector:
- **Green** wire to the rear left positive speaker output.
- **Green/Black** wire to the rear left negative speaker output.
- **Purple** wire to the rear right positive speaker output.
- **Purple/Black** wire to the rear right negative speaker output.
- **Yellow** RCA jack to the backup camera input.
- **Red & White** RCA jacks to the audio AUX-IN jacks (only if the factory AUX-IN jack is desired to be used).
- Tape off and disregard the following (2) wires, they will not be used in this application:
Blue/White labeled "500L amp turn on", **Red**
- Disregard the DIN jack, it will not be used in this application.

INSTALLATION

From: 6558

With the vehicle completely off:

1. Connect 16-pin connector to interface
2. Connect 22-pin connector to interface
3. From the **LD-BX-CH5** & **LD-CHRYTAC** harnesses, connect the 2-pins (labeled :1) to each other.
4. Connect the 2-pin (labeled HVAC to A)
5. Connect 6558 harness to vehicle
6. Connect the 12-pin of the **LD-CHRYTAC** to the HVAC LCD SCREEN
7. Locate the factory antenna connector in the dash and complete all necessary connections to the radio. Use the antenna adapter provided to adapt the factory antenna to the aftermarket radio.

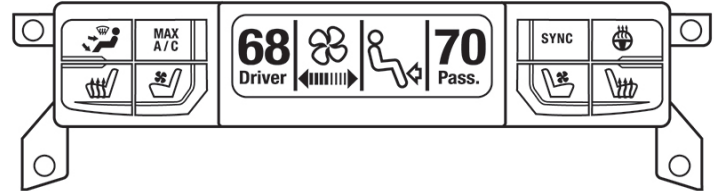
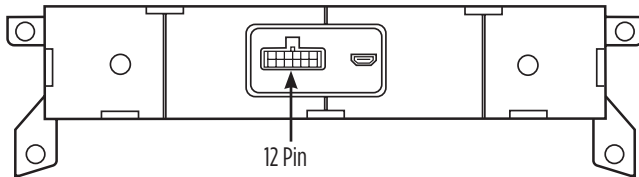

Description of button Assignments



Direction of air flow

**MAX
A / C**

Max A/C



Driver enable/disable heated seat



Driver enable/disable cool seat



Enable/disable heated steering wheel

SYNC

Synchronization of temperatures to match driver's



Passenger enable/disable heated seat



Passenger enable/disable cool seat



Fan Speed Control (push button to activate Auto)

Note: Heated seat, vented seat and heated steering wheel buttons have been included for vehicles with those options. Blank buttons have been included for vehicles without those options.

PROGRAMMING

For the steps below, the L.E.D. located inside the interface can only be seen while active. The interface does not need to be opened to see the L.E.D.

- Start the vehicle.
- Connect the **6558 harness** to the wiring harness in the vehicle.
- The L.E.D. will initially turn on solid Green, then turn off for a few seconds while it auto detects the radio installed.
- The L.E.D. will then flash **Red** up to (18) times indicating which radio is connected to the interface, and then turn off for a couple of seconds. Pay close attention to how many **Red** flashes there are. This will help in troubleshooting, if need be. Refer to the **L.E.D. feedback** section for more information.
- After a couple seconds the L.E.D. will turn on solid **Red** while the interface auto detects the vehicle. The radio will shut off at this point. This process should take 5 to 30 seconds.
- Once the vehicle has been auto detected by the interface, the L.E.D. will turn on solid **Green**, and the radio will come back on, indicating programming was successful.
- Test all functions of the installation for proper operation, before reassembling the dash.

If the interface fails to function, refer to **Resetting the AX-CH5-SWC**.

Note: The L.E.D. will turn on solid **Green** for a moment, and then turn off under normal operation after the key has been cycled.

STEERING WHEEL CONTROL SETTINGS

L.E.D. Feedback: The (23) **Red L.E.D.** flashes represent a different radio manufacturer for the **SWC interface** to detect. For example, if you are installing a **JVC** radio, the **SWC interface** will flash **Red** (5) times, then stop. Following is the **L.E.D Feedback Legend**, which indicates the flash count of the radio manufacturer.

L.E.D. Feedback Legend

Flash Count	Radio
1	Eclipse (type 1) †
2	Kenwood ‡
3	Clarion (type 1) †
4	Sony / Dual
5	JVC
6	Pioneer / Jensen
7	Alpine *
8	Visteon
9	Valor
10	Clarion (type 2) †
11	Metra OE
12	Eclipse (type 2) †

Flash Count	Radio
13	LG
14	Parrot**
15	XITE
16	Philips
17	TBA
18	JBL
19	Insane
20	Magnadyne
21	Boss
22	Axxera
23	Axxerra (type 2)

KEYNOTES

* If the **SWC interface** flashes **Red** (7) times, and an **Alpine** radio is not installed, that means there is an open connection not accounted for. Verify that the 3.5mm jack is connected to the correct steering wheel jack/wire in the radio.

** The **AXSWCH-PAR** is required (sold separately). Also, the software in the radio must be rev. 2.1.4 or higher.

† If a **Clarion** or **Eclipse** radio is installed and the steering wheel controls do not function, change the radio to **Clarion (type 2)** or **Eclipse (type 2)** respectively. If the steering wheel controls still do not function, refer to the **Changing Radio Type** document available at axxessinterfaces.com.

‡ If a **Kenwood** radio is installed and the L.E.D. feedback flashes (5) times instead of (2), manually change the radio type to **Kenwood**. To do this, refer to the **Changing Radio Type** document available at axxessinterfaces.com.

Continued on the next page

STEERING WHEEL CONTROL SETTINGS (CONT.)

Attention: The **Axxess Updater App** can also be used to program the following (3) sub-sections as well, pending that the interface has been initialized and programmed.

Changing radio type

If the LED flashes do not match the radio you have connected, you must manually program the **6558 interface** to tell it what radio it is connected to.

1. After (3) seconds of turning the key on, press and hold the Volume-Down button on the steering wheel until the L.E.D. in the AX-CH5-SWC goes solid.
2. Release the Volume-Down button; the L.E.D. will go out indicating we are now in Changing Radio Type mode.
3. Refer to the **Radio Legend** to know which radio number you would like to have programmed.
4. Press and hold the Volume-Up button until the L.E.D. goes solid, and then release. Repeat this step for the desired radio number you have selected.
5. Once the desired radio number has been selected, press and hold the Volume-Down button on the steering wheel until the L.E.D. goes solid. The L.E.D. will remain on for about (3) seconds while it stores the new radio information.
6. Once the L.E.D. goes off, the Changing Radio Type mode will then end. You can now test the steering control wheel controls.

Note: If at any time the user fails to press any button for a period longer than (10) seconds, this process will abort.

Radio Legend

- | | | | |
|---------------------|----------------------|----------------------|-------------|
| 1. Eclipse (Type 1) | 6. Pioneer/Jensen | 11. Metra OE | 16. Philips |
| 2. Kenwood | 7. Alpine | 12. Eclipse (Type 2) | 17. TBD |
| 3. Clarion (Type 1) | 8. Visteon | 13. LG | 18. JBL |
| 4. Sony/Dual | 9. Valor | 14. Parrot | |
| 5. JVC | 10. Clarion (Type 2) | 15. XITE | |

Continued on the next page

STEERING WHEEL CONTROL SETTINGS (CONT.)

Remapping the steering wheel control buttons

Let's say you have **6558 interface** initialized and you want to change the button assignment for the steering wheel controls. For example, you would like "Seek-Up" to be "Mute". Follow the steps below to remap the steering wheel control buttons:

1. Ensure the AX-CH5-SWC is visible so you can see the L.E.D. flashes to confirm button recognition.
Tip: Turning the radio off is recommended.
2. Within the first 20 seconds of turning the ignition on, press and hold the "Volume-Up" button on the steering wheel until the L.E.D. goes solid.
3. Release "Volume-Up", the L.E.D. will then go out; "Volume-Up" has now been programmed.

4. Follow the list in the **Button Assignment Legend**, to reference the order in which the steering wheel control buttons need to be programmed.

Note: If the next function on the list is not on the steering wheel, press the Volume-Up button for (1) second until the L.E.D. comes on, and then release the Volume-Up button. This will tell the 6558 interfacer that this function is not available and it will move on to the next function.

5. To complete the remapping process, press and hold the Volume-Up button on the steering wheel until the L.E.D. in the 6558 goes out.

Button Assignment Legend

1. Volume-Up	6. Mute	11. Play/Enter	15. Fan-Up *
2. Volume-Down	7. Preset-Up	12. PTT (Push to Talk)	16. Fan-Down *
3. Seek-Up/Next	8. Preset-Down	13. On-Hook	17. Temp-Up *
4. Seek-Down/Prev	9. Power	14. Off-Hook	18. Temp-Down *
5. Source/Mode	10. Band		

Note: Not all radios will have all of these commands. Please refer to the manual provided with the radio, or contact the radio manufacturer for specific commands recognized by that particular radio.

Continued on the next page

STEERING WHEEL CONTROL SETTINGS (CONT.)

Dual assignment instructions (long button press)

The **6558 interface** has the capability to assign (2) functions to a single button, except Volume-Up and Volume-Down. Follow the steps below to program the button(s) to your liking.

Note: Seek-Up and Seek-Down come pre-programmed as Preset-Up and Preset-Down for a long button press.

1. Turn on the ignition but do not start the vehicle.
2. Press and hold down the steering wheel control button that you want to assign a long press function to for about (10) seconds, or until the L.E.D. flashes rapidly. At this point release the button; the L.E.D. will then go solid.
3. Press and release the Volume-Up button the number of times corresponding to the new button number selected. Refer to the **Dual Assignment Legend**. The L.E.D. will flash rapidly while the Volume-Up button is being pressed, and then go back to a solid L.E.D. once released. Go to the next step once the Volume-Up button has been pressed the desired number of times.
Caution: If more than (10) seconds elapses between pressing the Volume-Up button, this procedure will abort, and the L.E.D. will go out.
4. To store the long press button in memory, press the button that you assigned a long press button to (the button held down in Step 2). The L.E.D. will now go off indicating the new information has been stored.

Note: These steps must be repeated for each button you would like to assign a dual purpose feature to. To reset a button back to its default state, repeat Step 1, and then press the Volume-Down button. The L.E.D. will go out, and the long press mapping for that button will be erased.

Dual Assignment Legend

- | | | | |
|-------------------|----------------|----------------|-----------------|
| 1. Not allowed | 6. ATT/Mute | 11. Play/Enter | 16. Fan-Down * |
| 2. Not allowed | 7. Preset-Up | 12. PTT | 17. Temp-Up * |
| 3. Seek-Up/Next | 8. Preset-Down | 13. On-Hook | 18. Temp-Down * |
| 4. Seek-Down/Prev | 9. Power | 14. Off-Hook | |
| 5. Mode/Source | 10. Band | 15. Fan-Up * | |

* Not applicable in this application

FACTORY CONTROL PANEL BUTTON FUNCTIONS

Factory Control panel will vary from vehicles (refer to images provided)

Note: Some factory controls are retained (ex. Audio and HVAC can be controlled from factory panel with our 95-6558 installed) the following buttons will not work or will perform a different action.

Buttons not working or have a different assignment

- Screen OFF : NA
- BACK : EXITS PREVIOUS SCREEN FROM VEHICLE OPTIONS SECTION
- Right Rotary Knob: will change to previous track or cycle through stations. (When button is pressed as “Enter” you will be able to cycle through the Vehicle options that were equipped with, by turning the knob and then pressing the enter once option is reached. Turn knob to make change on option(refer to owner’s manual for setting and selectable options)



8.4 NAV with Automatic Temperature Control

Resetting the 99-6558 interface

1. The Blue reset button is located inside the interface, between the two connectors. The button is accessible outside the interface, no need to open the interface.
2. Press and hold the reset button for two seconds, and then let go to reset the interface.
3. Refer to **“Programming the Interface”** from this point.

Redecting vehicle's vehicle options (Vehicle Options may vary, refer to vehicle's owner's manual for vehicle options that came equipped with vehicle) on the HVAC LCD.

1. With vehicle running (On Position/Ignition On)
2. Hold Sync and Max AC button for 8seconds (LCD will display DECTION IN PROGRESS XX/YY

FINAL ASSEMBLY

1. Snap the radio trim panel over the radio and reassemble the dash in reverse order of disassembly.



95-6558B
INSTALLATION INSTRUCTIONS



Having difficulties? We're here to help.



Contact our Tech Support line at:

386-257-1187



Or via email at:

techsupport@metra-autosound.com

Tech Support Hours (Eastern Standard Time)

Monday - Friday: 9:00 AM - 7:00 PM

Saturday: 10:00 AM - 5:00 PM

Sunday: 10:00 AM - 4:00 PM



KNOWLEDGE IS POWER

Enhance your installation and fabrication skills by enrolling in the most recognized and respected mobile electronics school in our industry. Log onto www.installerinstitute.edu or call 386-672-5771 for more information and take steps toward a better tomorrow.



Metra recommends MECP certified technicians