



Hyundai Elantra 2019-2020

Visit MetraOnline.com for more detailed information about the product and up-to-date vehicle specific applications

KIT FEATURES

- ISO DDIN radio provision
- Painted scratch resistant matte black

KIT COMPONENTS

- A) Radio trim panel • B) Radio brackets • C) Blank panel • D) Blank panel clip legs (2) • E) #6 x 3/8" Phillips screws (2)
- F) #8 x 1/4" Phillips screws (4) • G) Panel clips (2)

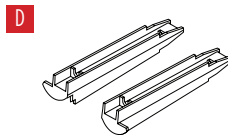
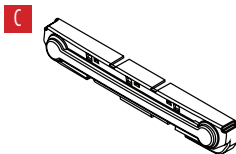
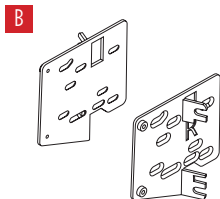
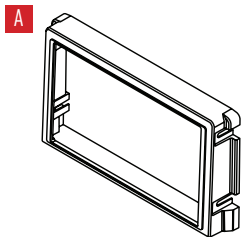

TABLE OF CONTENTS

Dash Disassembly	2
Kit Assembly	3

WIRING & ANTENNA CONNECTIONS (sold separately)

- Wiring Harness: 70-7304 (w/o 7-inch display radio)
- 70-7306 (with 7-inch display radio)
- Antenna Adapter: N/A (w/o 7-inch display radio)
- 40-K111 (with 7-inch display radio)

Please visit metraonline.com or axessinterfaces.com for other harness and interface options.

TOOLS REQUIRED

- Panel removal tool • Phillips screwdriver
- Socket wrench

Attention! With the key out of the ignition, disconnect the negative battery terminal before installing this product. Ensure that all installation connections are secure before cycling the ignition to test this product.

DASH DISASSEMBLY

1. Open the passenger front door, then unclip and remove the trim panel from the side of dashboard. Remove the (1) Phillips screw securing the silver trim panel. (Figure A)
2. Unclip and remove the silver trim panel that runs along the dashboard from under the radio, and above the glovebox. (Figure B)
3. Open the driver's door, then unclip and remove the trim panel from the side of the dashboard. Remove the (1) Phillips screw securing the silver trim panel. (Figure C)

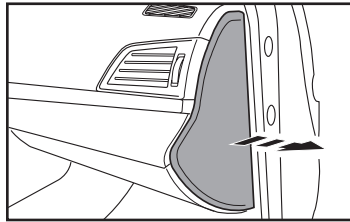

(Figure A)

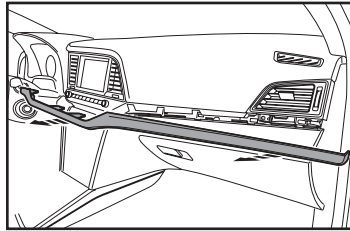

(Figure B)

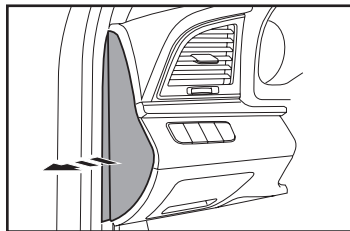

(Figure C)

4. Unclip and remove the silver trim panel from under the driver's side A/C vent. (Figure D)
5. Unclip the trim panel above the steering column, and then unclip and remove the entire panel surrounding the instrument cluster. Note, these two panels are one assembly. (Figure E)
6. Remove the (2) Phillips screws securing the radio trim panel, then unclip and remove the panel. (Figure F)
7. Remove the (4) Phillips screws securing the radio and then remove.

Continue to Kit Assembly

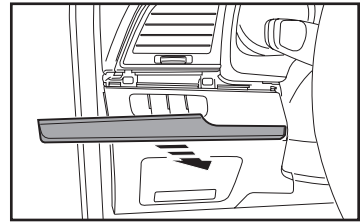

(Figure D)

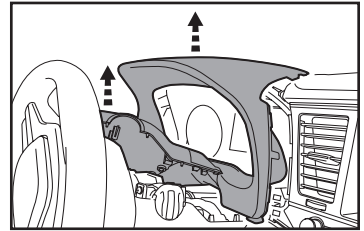

(Figure E)

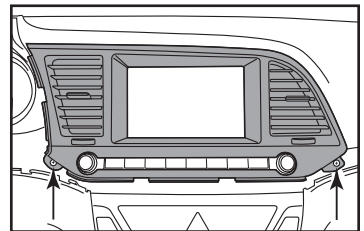

(Figure F)

KIT ASSEMBLY

1. Attach the **radio brackets** to the **radio trim panel** using (4) #8 x 1/4" Phillips screws supplied. (Figure A)
2. Slide the radio into the completed assembly, and then secure it to the assembly using screws supplied with the radio. (Figure B)
3. Attach the **blank panel clip legs** to the **blank panel** using (2) #6 X 3/8" Phillips screws supplied. (Figure C)
4. Attach the **panel clips** to the **panel legs**. (Figure D)

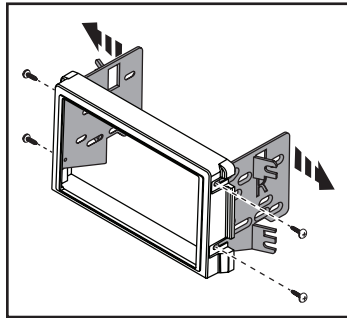

(Figure A)

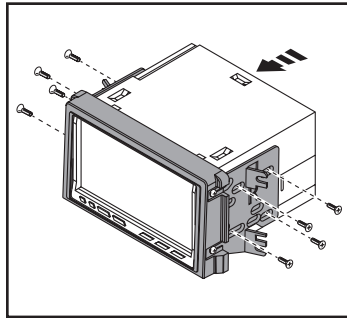

(Figure B)

5. Snap the **blank panel** into the factory trim panel. (Figure E)
6. Locate the factory wiring harness and antenna connector in the dash, and complete all necessary connections to the radio. Metra recommends using the proper mating adapter from Metra and/or AXCESS. Re-connect the negative battery terminal and test the radio for proper operation.
7. Reassemble the dash in reverse order of disassembly.

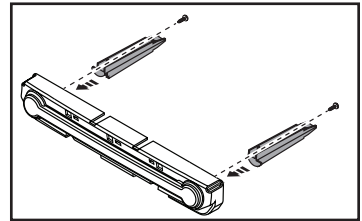

(Figure C)

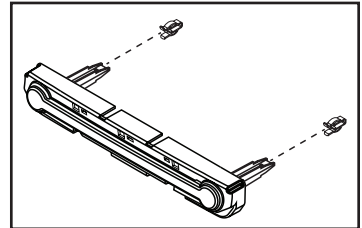

(Figure D)

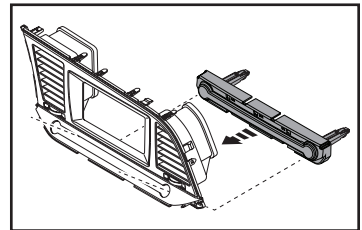

(Figure E)



95-7399B
INSTALLATION INSTRUCTIONS



Having difficulties? We're here to help.



Contact our Tech Support line at:

386-257-1187



Or via email at:

techsupport@metra-autosound.com

Tech Support Hours (Eastern Standard Time)

Monday - Friday: 9:00 AM - 7:00 PM

Saturday: 10:00 AM - 7:00 PM

Sunday: 10:00 AM - 4:00 PM



KNOWLEDGE IS POWER

Enhance your installation and fabrication skills by enrolling in the most recognized and respected mobile electronics school in our industry. Log onto www.installerinstitute.edu or call 386-672-5771 for more information and take steps toward a better tomorrow.



Metra recommends MECP certified technicians



Hyundai Elantra 2019-2020

Visite MetraOnline.com para obtener información más detallada sobre el producto y aplicaciones actualizadas específicas para vehículos.

CARACTERÍSTICAS DEL KIT

- Provisión de radio ISO DDIN
- Negro mate resistente a rayaduras

COMPONENTES DEL KIT

- A) Panel de moldura para radio • B) Soportes del radio • C) Panel vacío • D) Patas de gancho del panel vacío (2)
- E) Tornillos Phillips #6 x 3/8" (2) • F) Tornillos Phillips #8 x 1/4" (4) • G) Ganchos para panel (2)

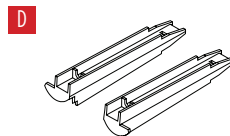
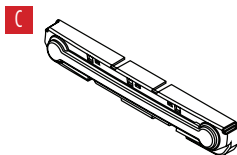
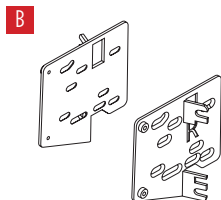
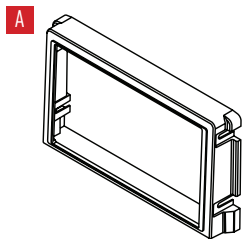

INDICE

Desmontaje del tablero	2
Ensamble del kit	3

CABLEADO Y CONEXIONES DE ANTENA

(se venden por separado)

Arnés de cableado: 70-7304

(sin radio de pantalla de 7 pulgadas)

- 70-7306 (con radio de pantalla de 7 pulgadas)

Adaptador de antena: N/D

(sin radio de pantalla de 7 pulgadas)

- 40-K111 (con radio de pantalla de 7 pulgadas)

Consulte el sitio metraonline.com o axessinterfacs.com para más opciones de arneses e interfaces

HERRAMIENTAS REQUERIDAS

- Herramienta para quitar paneles
- Destornillador Phillips • Llave de tubo

¡Atención! Deje que el vehículo se asiente con la llave fuera del encendido durante unos minutos antes de quitar la radio de fábrica. Al probar el equipo del mercado de accesorios, asegúrese de que todo el equipo de fábrica esté conectado antes de encender el llave de encendido.

DESMONTAJE DEL TABLERO

1. Abra la puerta del copiloto. Después, desenganche y quite el panel de moldura del lado del tablero. Quite el (1) tornillo Phillips que sujeta el panel de la moldura plateado. (Figura A)
2. Desenganche y quite el panel de moldura plateado que corre a lo largo del tablero desde la parte inferior del radio y encima de la guantera. (Figura B)
3. Abra la puerta del conductor. Después, desenganche y quite el panel de moldura del lado del tablero. Quite el (1) tornillo Phillips que sujeta el panel de la moldura plateado. (Figura C)

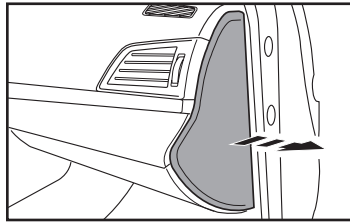

(Figura A)

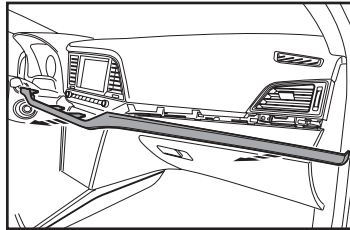

(Figura B)

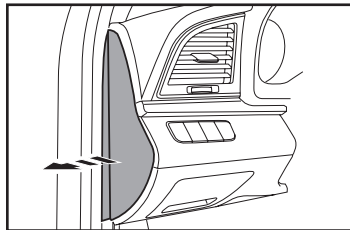

(Figura C)

4. Desenganche y quite el panel de moldura plateado desde abajo de la rejilla de aire acondicionado del copiloto. (Figura D)
5. Quite el panel de moldura que está encima de la columna de dirección. Después, desenganche y quite todo el panel que rodea al panel de instrumentos. Preste atención porque estos dos paneles son un ensamble de una sola pieza. (Figura E)
6. Quite los (2) tornillos Phillips que fijan el panel de moldura para radio. Después, desenganche y quite el panel. (Figura F)
7. Quite los (4) tornillos Phillips que sujetan el radio y quítelo.

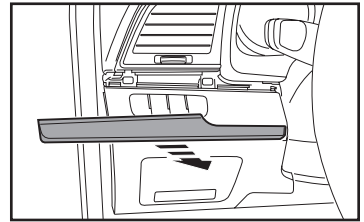

(Figura D)

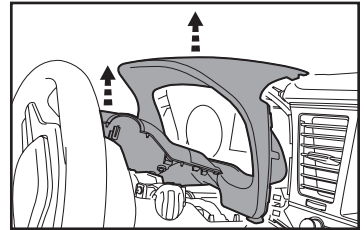

(Figura E)

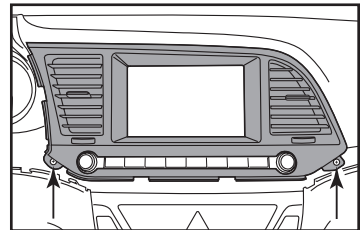

(Figura F)

Continúe con el ensamble del kit

ENSAMBLE DEL KIT

1. Una los **soportes del radio** al **panel de moldura del radio** usando (4) tornillos Phillips #8 x 1/4" incluidos. (Figura A)
2. Deslice el radio hacia dentro del ensamble terminado. Después, fíjelo al ensamble con los tornillos incluidos con el radio. (Figura B)
3. Una las patas de los **ganchos del panel vacío** al **panel vacío** usando (2) tornillos Phillips #6 X 3/8" incluidos. (Figura C)
4. Una los **ganchos del panel** a las **patas del panel**. (Figura D)

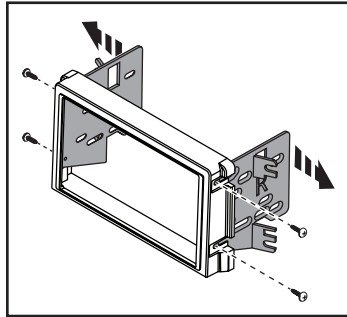

(Figura A)

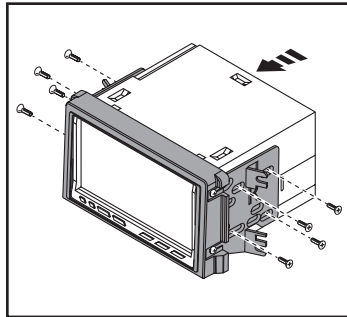

(Figura B)

5. Meta el **panel vacío** a presión en el panel de moldura de fábrica. (Figura E)
6. Ubique el arnés de cableado de fábrica y el conector de la antena en el tablero y realice todas las conexiones necesarias al radio. Metra recomienda el uso de adaptadores de acoplamiento adecuados de Metra o de AXCESS. Vuelva a conectar la terminal negativa de la batería y haga pruebas en el radio para confirmar que funciona correctamente.
7. Vuelva a armar el tablero en el orden inverso de como lo desarmó.

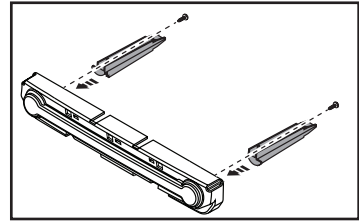

(Figura C)

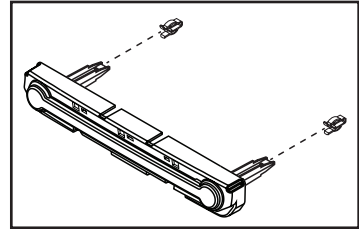

(Figura D)

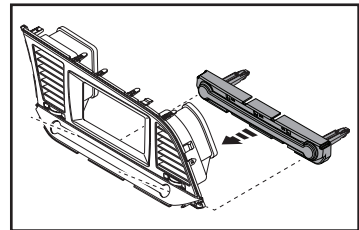

(Figura E)



95-7399B
INSTRUCCIONES DE INSTALACIÓN



¿Tienes dificultades? Estamos aquí para ayudar.



Póngase en contacto con nuestra
línea de soporte técnico en:
386-257-1187



O por correo electrónico a:
techsupport@metra-autosound.com

Horas de soporte técnico (hora estándar del este)

Monday - Friday: 9:00 AM - 7:00 PM

Saturday: 10:00 AM - 7:00 PM

Sunday: 10:00 AM - 4:00 PM



KNOWLEDGE IS POWER

Enhance your installation and fabrication skills by enrolling in the most recognized and respected mobile electronics school in our industry. Log onto www.installerinstitute.com or call 800-354-6782 for more information and take steps toward a better tomorrow.



**Metra recomienda MECP
técnicos certificados**